

INSTRUCTION MANUAL

15ppm Bilge Alarm

Type OMD-2008

DECKMA HAMBURG GmbH

Kieler Straße 316, D-22525 Hamburg - Germany
Tel.: +49 (0) 40 54 88 76-0, Fax: +49 (0) 40 54 88 76-10
Internet: www.deckma.com eMail: post@deckma.com

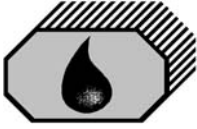

IMPORTANT NOTICE

Replacement components for 15ppm Bilge Alarms.

General

All monitors in our range are inspected and tested to the related I.M.O. requirements at our factories prior to delivery.

In normal use the units should operate correctly and without fault over a long period of time requiring only small amounts of maintenance to be carried out as outlined in the instruction manuals.

Service Exchange Units

In the event of a monitor malfunction due to electrical or electronic component failure it is our recommendation that a service exchange unit be ordered.

The defective instrument should be returned to our works within 30 days of supplying the service exchange unit, then only the repair charge is payable. Otherwise the whole cost of a service exchange unit becomes payable.

This procedure is by far the easiest and most cost effective way of ensuring the monitor on board conforms to I.M.O. resolution MEPC.107 (49).

Remark:

According the MEPC.107(49) § 4.2.11 the unit has to be checked at IOPP Certificate renewal survey by the manufacturer or persons authorized by the manufacturer. Alternatively the unit may be replaced by a calibrated 15 ppm Bilge Alarm. The OMD-2008 is designed in that way, that only the measuring cell needs to be changed, as this unit carry the calibration onboard. The Calibration Certificate with the date of the last calibration check should be retained onboard for inspection purposes.

If for some reasons the computer unit needs to be changed, it has to make sure, that the memory card will remain on board for at least 18 month. The new computer unit will carry its own memory card. The old card can be insert into the new unit only for reading. Writing is only possible with the card delivered with the new computer unit. For details see section 13.1.

Warranty

Our warranty terms are 12 months after installation but maximal 18 months after delivery ex works. The maker undertakes to remedy any defect resulting from faulty materials of workmanship except wearing parts.

The maker's obligation is limited to the repairs or replacement of such defective parts by his own plant or one of his authorized service stations.

The purchaser shall bear the cost and risk of transport of defective parts and repaired parts supplied in replacement of such defective parts.

ANY DISMANTLING OR BREAKING OF A SEAL WILL VOID THE WARRANTY

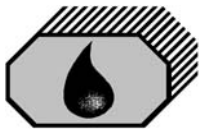

CONTENTS

| SECTION | TITLE | PAGE |
|---------|-------------------------------------|------|
| 1.0 | Introduction | 4 |
| 2.0 | Important Notes | 4 |
| 3.0 | Principle of Operation | 5 |
| 3.1 | Measuring Principle | 5 |
| 3.2 | Features | 5 |
| 3.3 | Adjustment | 5 |
| 3.4 | Displays and Alarms | 5 |
| 4.0 | Specification | 7 |
| 5.0 | Construction | 8 |
| 6.0 | Installation | 9 |
| 7.0 | Piping | 10 |
| 8.0 | Wiring | 11 |
| 8.1 | Typical Control System | 13 |
| 9.0 | Power Supply | 13 |
| 10.0 | Commissioning | 13 |
| 10.1 | Electrical | 13 |
| 10.2 | Piping | 13 |
| 10.3 | Functional Tests | 14 |
| 10.4 | Programming Mode | 15 |
| 11.0 | Operating Instructions | 19 |
| 11.1 | Operator Notes | 20 |
| 12.0 | Operator Maintenance | 20 |
| 12.1 | Manual Cell Clean Unit | 21 |
| 13.0 | Fault Finding | 22 |
| 13.1 | Memory Card | 24 |
| 14.0 | Calibration | 25 |
| 14.1 | Calibration and Repeatability Check | 25 |
| 15.0 | Spare Parts | 26 |
| 15.1 | Recommended On Board Spares | 26 |
| 16.0 | Remarks | 27 |

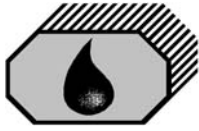

1.0 INTRODUCTION

The OMD-2008 Bilge Alarm Unit has been designed specifically for use in conjunction with 15 ppm oil-water separator units and has a specification and performance which exceeds the requirements of the International Maritime Organization specifications for 15ppm Bilge Alarms contained in Resolution MEPC. 107 (49).

The unit is supplied with 2 works-adjusted alarms at 15 ppm. Other set points (10 ppm or 5 ppm) are possible and can be adjusted on site at any time by using the buttons at the front panel.

If an alarm set point is exceeded, the alarms are visible at the front panel and the appropriate relays are switched. In case of malfunction the System LED at the front panel will change from blinking green to permanent red.

For the data logging function the unit requires an status input from the separator.

A 0(4) - 20 mA (equal to 0 - 30 ppm) signal output is available for driving a recorder or external meter.

2.0 IMPORTANT NOTES

- a) This equipment must be installed and operated in strict accordance with the instructions contained in this manual. Failure to do so will impair the protection provided.
- b) Installation and servicing must be undertaken by a competent and suitable skilled person.
- c) The equipment must be connected to the ground according relevant requirements.
- d) The unit must be isolated from the electrical supply before any maintenance of the equipment is attempted.
- e) All National or local codes of practice or regulations must be observed and, where applicable, are deemed to take precedence over any directive or information contained in this manual.
- f) In case of freezing conditions the measuring cell should be emptied complete.

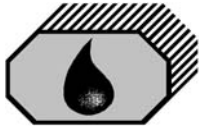

3.0 PRINCIPLE OF OPERATION

3.1 Measuring Principle

An optical sensor array measure a combination of light scattered and absorbed by oil droplets in the sample stream. The sensor signals are then processed by a microprocessor to produce linearised output.

If an alarm (works set point 15 ppm) occurs, the two oil alarm relays are activated after the adjusted time delay.

The microprocessor continuously monitors the condition of the sensor components and associated electronics to ensure that calibration accuracy is maintained over time and extremes of environmental conditions.

3.2 Features

- Robust construction
- Solid suppression capability
- Low maintenance
- Easy installation
- Constant readiness
- Low spare part stock holding
- Works adjustment
- Easy settings via menu

3.3 Adjustment

The unit is delivered with a works calibration according the IMO-requirements. The alarm points are set to 15 ppm.

The "Zero" point is also works calibrated and can be re-adjusted on site by using the programming mode and clean water. See Section 10.4 "Settings-Offset". A calibration is not permitted. This has to be done according IMO Regulations by the manufacturer or persons authorized by the manufacturer.

3.4 Displays and Alarms

In the unit are two independent oil alarm circuits available. Both can be set separately from 1 to 15 ppm. From the manufacturing both alarms are set to 15 ppm (according IMO). The set points can be changed according to the requirements on site, for example to 10 ppm or 5 ppm. An alarm point setting above 15 ppm is not possible. The adjustment can be done in the programming mode as described in Section 10.4.

In this mode also the individual adjustment of the time delays for the alarms can be done.

Both alarm circuits are also related to an alarm LED on the front panel.

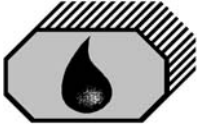

DECKMA HAMBURG GmbH

In case of malfunction the “System” LED will indicate any type of internal fault of the unit. This LED is flashing green in normal conditions and is red in alarm conditions.

Additional to the alarm LEDs each alarm circuit is equipped with a relay with potential free alarm contacts. These contacts can be used for external processing of the signal or for control of further functions.

If a malfunction or failure of the power supply occurs, all three relays (both alarm relays and the SYSTEMFAULT relay) will switch to alarm condition.

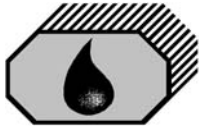

4.0 SPECIFICATION OMD-2008

| | |
|--|---|
| Range: | 0 – 30 ppm, Trend indication 50ppm |
| Accuracy | According IMO MEPC. 107(49) |
| Linearity | Up to 30 ppm better than $\pm 2 \%$ |
| Display | Yellow Graphic Display |
| Power Supply: | 24 V - 240V AC or DC Automatic Voltage selection |
| Consumption: | < 10 VA |
| Alarm Points 1 + 2: | Adjustable between 1 - 15 ppm (Works adjustment 15 ppm) |
| Alarm 1 Operating Delay: (for annunciation purpose) | Adjustable between 1 – 540 sec. (Works adjustment 2 sec) |
| Alarm 2 Operating Delay: (for control purposes) | Adjustable between 1 – 10 sec. (Works adjustment 10 sec) |
| System Fault Alarm: | Red LED |
| Alarm Contact Rating: | Potential free 1 pole change over contacts, 3 A / 240 V |
| Alarm Indication: | Red LEDs |
| Output Signal: | 0 – 20 mA or 4 – 20 selectable ext. Load < 150 Ω |
| Sample Water Pressure: | 0,1 – 10 bar |
| Sample Flow: | Approx. 0,1 - 3 l/min depending on pressure |
| Ambient Temperature: | + 1 to + 55° C |
| Sample Water Temperature: | + 1 to + 65° C |
| Roll: | Up to 45° |
| Size (over all) | 360 mm W x 240 mm H x 100 mm D |
| Degree of Protection: | IP 65 |
| Weight: | 5,4 kg |
| Pipe Connections: | R 1/4" Female |

Technical specifications are subject to change without notification

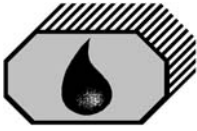

5.0 CONSTRUCTION

There are 2 main parts which contained in an OMD-2008:

The computer unit contains the display PCB with the data logger and the terminals for external connections.

The measuring cell is built out of an anodized all-aluminium body with inlet and outlet block in stainless steel. This rugged cell contains optics and electronics and is connected with the computer unit via a plugged data cable.

It is mounted onto a stainless steel support that also holds the valve assembly. The valve handle controls sample water flow and clean water usage.

The OMD-2008 can easily be mounted in wall or bulkhead installation. It is also possible to split the computer unit from the measuring cell. For this version separate mounting plates are available.

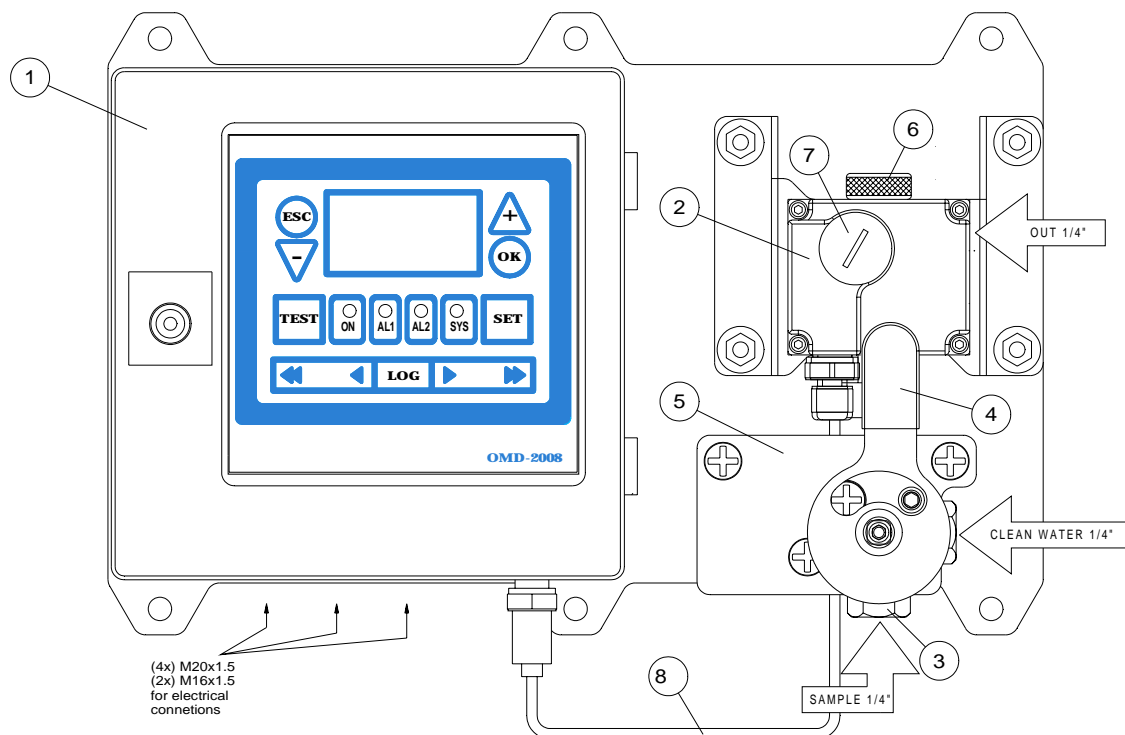

| | | | | | |
|---|-------------------------------------|---|--------------|---|---------------------|
| 1 | Computer Unit | 4 | Valve Handle | 7 | Dessicator Cap |
| 2 | Measuring Cell | 5 | Valve Plate | 8 | Communication Cable |
| 3 | Sample&Clean Water Switchover Valve | 6 | Head Screw | | |

Fig. 1

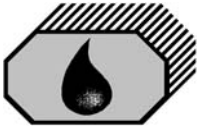

6.0 INSTALLATION (Refer to Fig. 2 and Fig. 3)

See Section 2 for important notes concerning installation.

The OMD-2008 Monitor should be located as close as possible to the oily water separator to minimize response delays. According MEPC.107(49) the layout of the installation should be arranged so that the overall response time (including the response time of the 15 ppm Bilge Alarm, which is less than 5 s.) between an effluent discharge from the 15 ppm Bilge Separator exceeding 15 ppm, and the operation of the Automatic Stopping Device preventing overboard discharge, should be as short as possible and in any case not more than 20 s.

Mount the OMD-2008 Monitor by means of M6 or M8 screws on to a rigid vertical surface and preferably with the display panel of the monitor at eye level. For service and maintenance sufficient space to all sides should be available.

Care must be taken at mounting of the pipes connections to avoid any torsion of the housing and damage of the instrument.

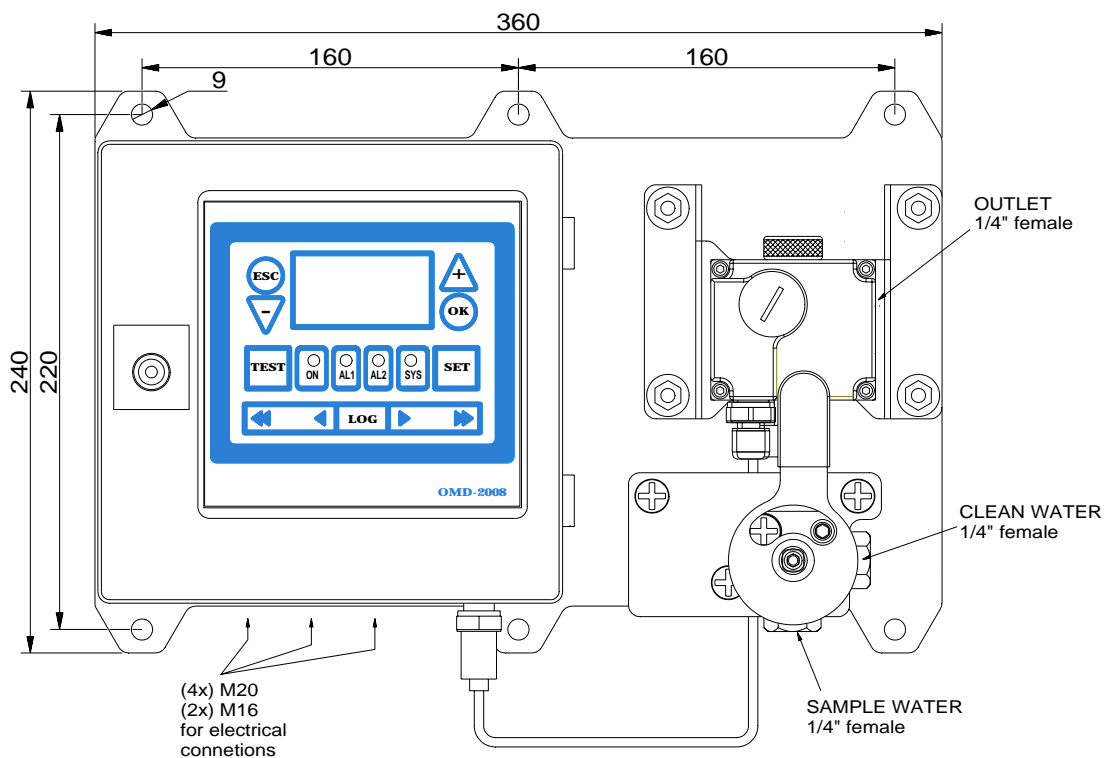
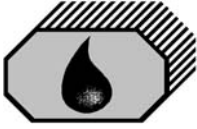

Fig. 2



7.0 PIPING (Refer to Fig. 3)

Connect the OMD-2008 Monitor to the sample point of the oily-water separator outlet and to a source of oil free water employing 10 mm OD copper or stainless steel pipe. The sample point should be located on a vertical section of the separator outflow piping to minimize the effects of any entrained air. The tapping point should be at a level above the outlet of the monitor to ensure the sample cell is flooded at all times.

If connection to a vertical section of the separator outlet piping is impractical, the tapping may be made into the side of the horizontal pipe. Avoid top or bottom entry.

For separator discharge pipes up to 75 mm OD a standard "T"-type junction of the welded or screwed type is satisfactory for the tapping point. For the separator discharge pipes of 80 mm OD and above a sample probe should be employed which protrudes into the discharge piping by approx. 25 % of the ID of the pipe.

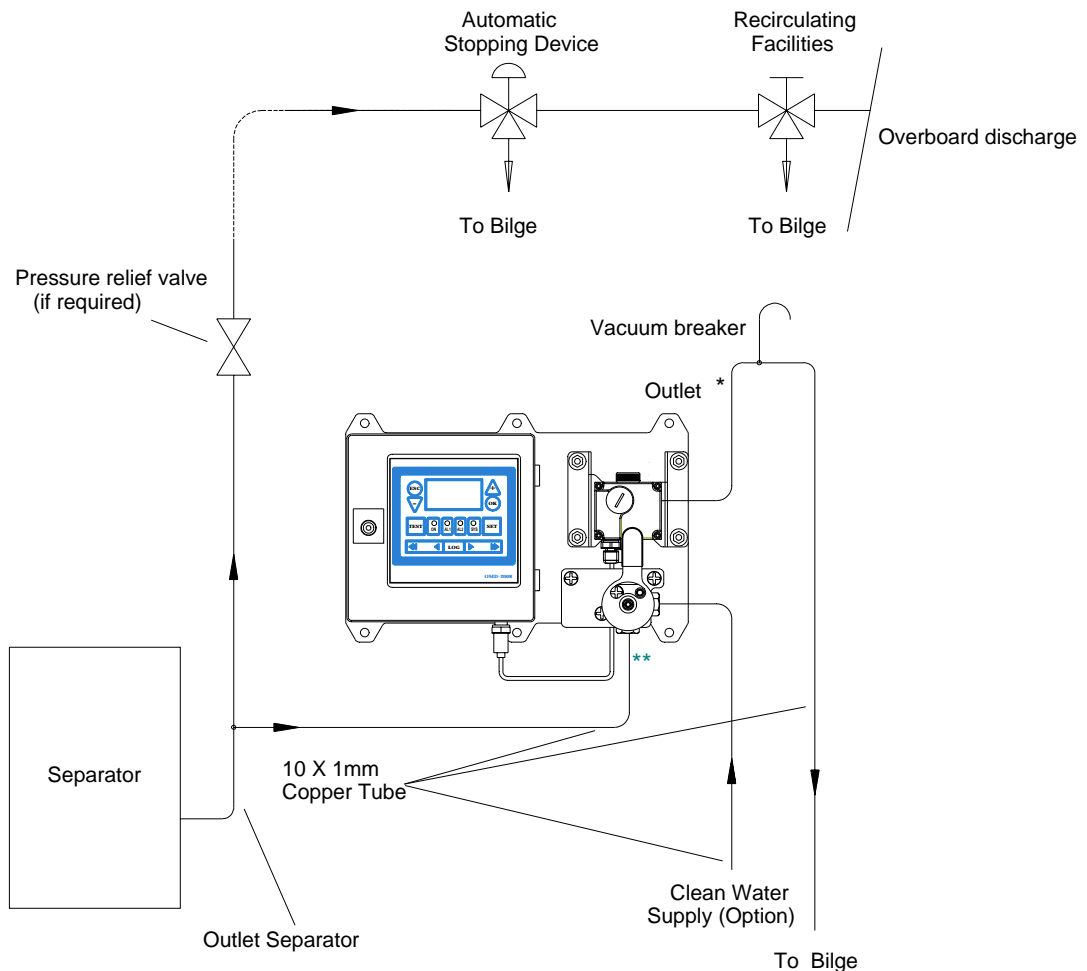
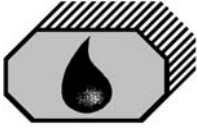

Fig. 3

* Inlet & Outlet connections R1/4" Female

** Optional electric switchover valve DH79450 according to makers instructions allowable



8.0 WIRING (Refer to Fig. 4 + 5)

See Section 2 for important notes concerning wiring.

This unit must be connected to the mains supply via a suitable rated and approved fused isolator unless such fusing / isolation is provided by associated equipment. When fitted, the isolator should be close, readily accessible and marked as to function.

Electrical connections are made through the metric cable gland openings prepared underneath the instrument.

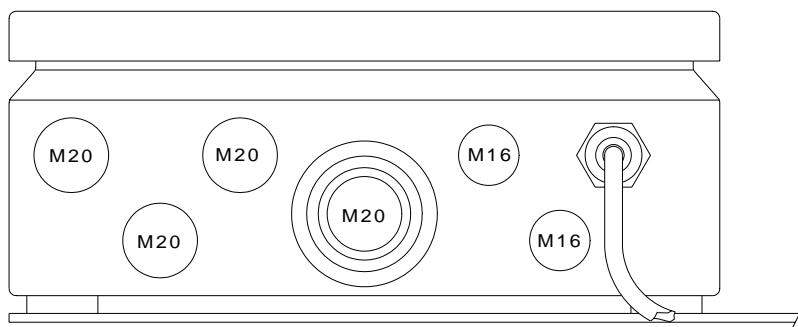

Fig. 4

Precise wiring details will vary dependent upon the control system to be employed but the most frequently used systems employ alarm relay 1 for alarm only and alarm relay 2 for control purposes.

Electrical connections are made to the terminal blocks inside the computer housing. Wires are connected to the terminals by pushing a suitable screwdriver into the clamp holes to release the internal spring loaded clamps. After the wire is inserted to the terminal and the screwdriver is removed, the wire is fixed.

If the instrument is operated at high voltages, additional care has to be taken to provide reliable ground connections. Ground (PE) can be connected direct to the terminal or, if this is not sufficient according local rules, to the computer housing (PE bolt inside, right side).

The instrument provides a pilot voltage output at Terminals 3&4. This is internally connected to the power supply input (Terminals 1&2 via Fuse T2A). The pilot voltage can be used to supply additional external circuitry, e.g. alarm lamps or electrical valves.

Please note: any device connected to the pilot voltage output must be rated for the voltage the instrument is supplied with. Do not use the pilot voltage for driving motors, heaters or other high load devices. The pilot voltage is intended for alarm purposes only.

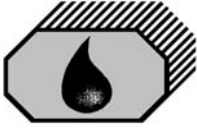

- 1-2 Power Supply
- 3-4 Pilot Voltage Output (Same as Power Supply)
- 5-7 Potential free Output Alarm 1 (Change over contact)
- 8-10 Potential free Output Alarm 2 (Change over contact)
- 11-12 Input Status Switch from Separator (Close when running)
- 13-14 Input Reserved for future use
- 15-16 Input Flow Direction Switch (Deckma Delivery)
- 17-18 (Optional) Signal Output 0(4) to 20 mA
- 19-20 Input External Fresh Water Usage
- 21-22 Output External Fresh Water Valve (Deckma Delivery)
- 23-25 Potential free Output System Fault (Change over contact)

POWER SUPPLY MUST HAVE FUSE T2A

POWER SUPPLY 24V-240V AC/DC

LINK TERMINALS 15&16 IF NO FLOW SWITCH IS PRESENT

EXAMPLE

Connections may vary with different separator control boxes

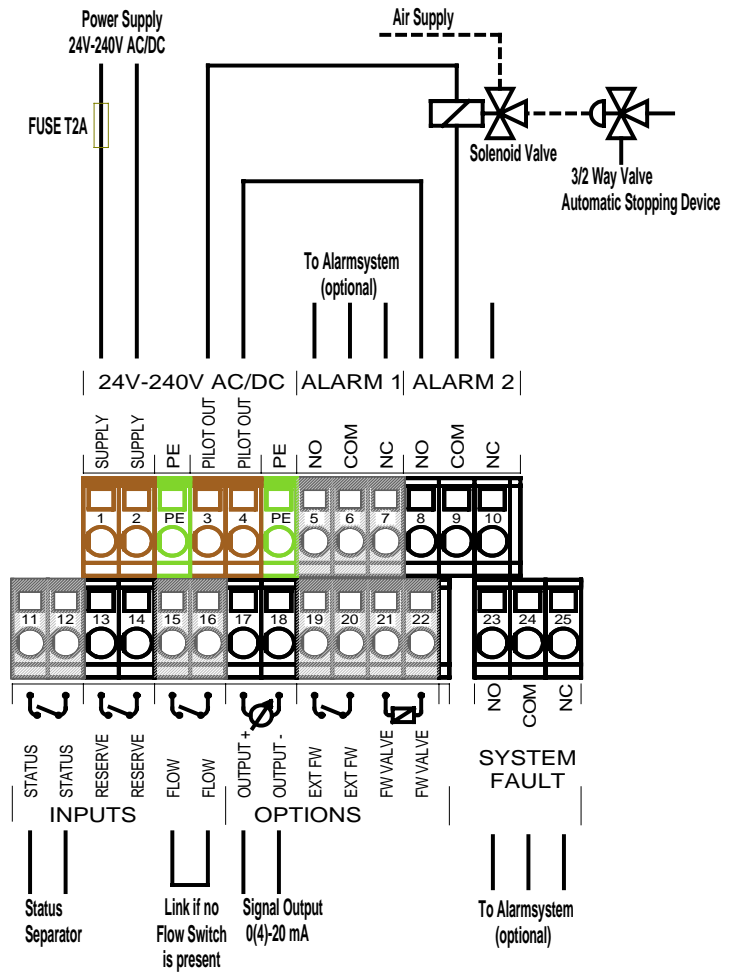
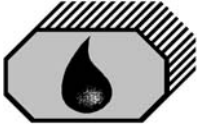

Fig. 5

Close front cover complete after electrical installation. Water inside the instrument may result in corrosion and malfunction. Alarm contacts description is in alarm (non-energized) condition.

Note: In case the OMD-2008 is installed as replacement to an MEPC 60.(33) approved separator and no "Status Separator" signal is available, this can be simulated by installing a link across terminal 11 + 12.



8.1 Typical Control System

The installation on site has to make sure that in case of any loss of power supply and/or loss of air supply for the automatic stopping device the overboard discharge valve close the overboard line and open the re-circulating line.

The system showed in the example, employs alarm relay 2 to control a pneumatic solenoid valve which energises or de-energises a pneumatically operated 3 - way valve as depicted in Fig. 5.

The separation process will continue until such time as the pollution level falls below the alarm set point at which time the discharge will be directed overboard.

A pump stop system is according MEPC.107 (49) not allowed.

9.0 POWER SUPPLY

See Section 2 for important notes.

The unit is designed for a power supply of 24 V to 240 V AC or DC. It has an automatic voltage selection. The power supply must have a fuse rated no more than 2A.

10.0 COMMISSIONING

See Section 2 for important notes.

On completion of the installation, wiring and piping carry out the following checks:

10.1 Electrical

- a) Check that the power supply is connected to the terminals 1 + 2 of the terminal block.
- b) Check the wiring of the automatic stopping device and to the alarm system is according the IMO Requirements.
- c) Check that the grounding has been made according to the relevant regulations.

10.2 Piping

- a) Check all piping connections for leaks and rectify as appropriate.

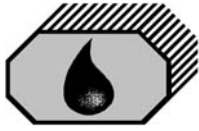

10.3 Functional Tests

- Run oil free water through the instrument to purge the system.
- Adjust the flow rate through the unit by using the small O-Rings in the cell cap.

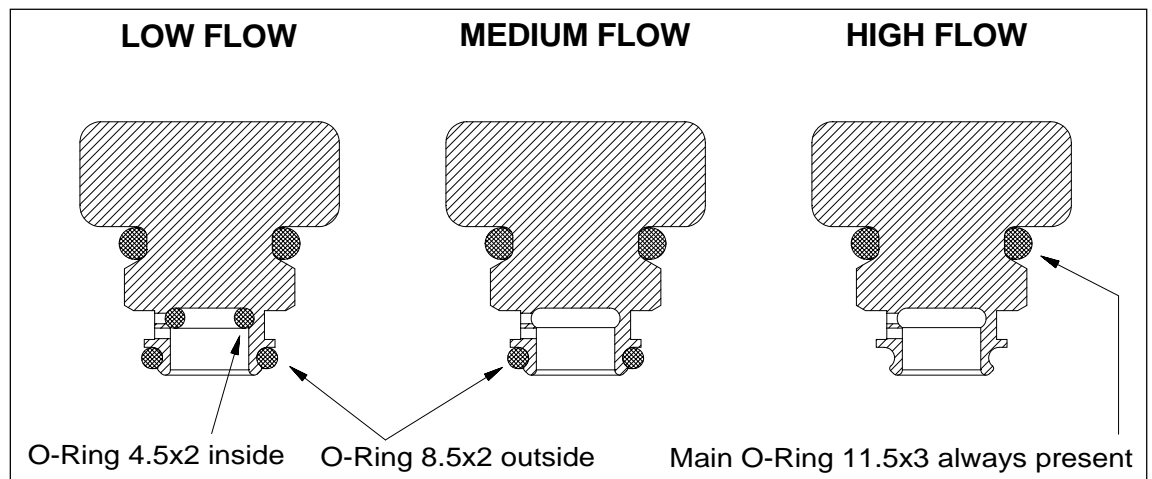

NB: The flow rate should be checked on both, the clean water supply and the separator sample supply. If the clean water supply is obtained from a high pressure source, the flow rate will be higher than from the sample point.

The flow rate is not influencing the accuracy of the instrument. The adjustment is only important for the time delay between the sample point and the monitor.

- Switch on the instrument and make sure, that the Power LED is illuminated and the display is showing the initializing display for about 15 sec. After that time it will change to the standard display, showing the actual measurement.

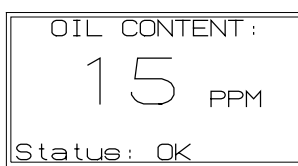
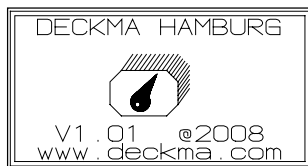

- During oil free water is running through the monitor check the Zero adjustment. The display should be "0" to "2" and the status will show "FW". If the display varies by greater amounts, it may be that air entrainment is present. If this is the case, the cause must be located and rectified.

- If the Zero need to be adjusted, this can be done in the programming mode as described in section 10.4. (Settings – Offset)

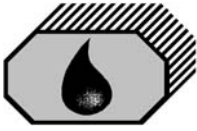

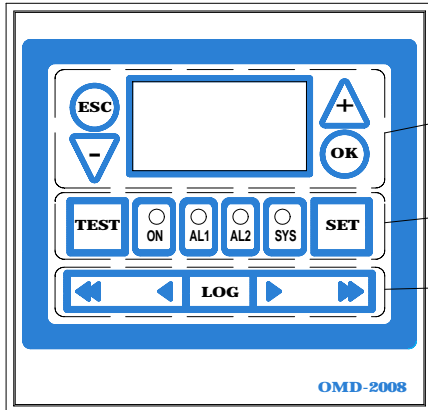

10.4 Programming Mode



There are 3 groups of push buttons to control the functions of the display. Navigation buttons are in group 1. Functional buttons are group 2. Group 3 is for data logger operation.

In the programming mode the alarm set points, the time delays, and the offsets can be modified. It is also possible to reset to the factory default values at any time.

The clock is factory set for GMT, **Greenwich Mean Time**, and cannot be changed.

| | | |
|--|--|--|
| <div data-bbox="379 969 691 1131" data-label="Image"> </div> <p>Initial Display.</p> <p>Will disappear a few seconds after power up.</p> | <div data-bbox="767 969 1067 1131" data-label="Image"> </div> <p>Normal Operation Display.</p> <p>Pressing the  button will display additional information.</p> <p>Pressing the  button will display more detailed information about the current status.</p> | <div data-bbox="1134 969 1442 1131" data-label="Image"> </div> <p>Exit from SYSTEM-info menu by pressing the ESC button.</p> <p>Refer to Fault finding table in manual for explanations of status information.</p> |
|--|--|--|

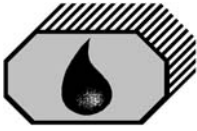

| | | |
|---|--|---|
| <div style="display: flex; justify-content: space-around;"> <div style="border: 1px solid blue; padding: 5px; text-align: center;">○ AL1</div> <div style="border: 1px solid blue; padding: 5px; text-align: center;">○ AL2</div> </div> <p>Pressing the AL1 button leads into SETTINGS menu, Alarm1 settings preselected.</p> <p>Pressing the AL2 button leads into SETTINGS menu, Alarm2 settings preselected.</p> <div style="text-align: center; margin-top: 20px;"> <div style="border: 2px solid blue; padding: 10px; width: 60px; margin: 0 auto;"> SET </div> </div> <p>Pressing the SET button from Normal Operations Display leads into SETTINGS menu, set default option preselected.</p> | <div style="border: 1px solid black; padding: 5px; font-family: monospace;"> SETTINGS →Alarm 1: 15ppm Delay 1: 2sec Alarm 2: 15ppm Delay 2: 10sec Offset: 0ppm Output: 0-20mA set default </div> <p>At the SETTINGS menu the alarms, time delays, the Offset and optionally the output signal can be modified within the limitations. Select the required point by using the „+“ or „-“ button. To modify settings press the button.</p> | <div style="border: 1px solid black; padding: 5px; font-family: monospace;"> ALARM 1, VALUE min.: 1ppm →: 15ppm max.: 15ppm set default: 15ppm confirm with OK </div> <p>To change the value, press the „+“ or „-“ button. Confirm with “OK”.</p> <div style="border: 1px solid black; padding: 5px; font-family: monospace;"> ALARM 2, DELAY min.: 1sec →: 10sec max.: 10sec set default: 10sec confirm with OK </div> <p>To change the value, press the „+“ or „-“ button. Confirm with “OK”.</p> <div style="border: 1px solid black; padding: 5px; font-family: monospace;"> OFFSET min.: -5ppm →: 0ppm max.: 5ppm set default: 0ppm confirm with OK </div> <p>To change the value, press the „+“ or „-“ button. Confirm with “OK”.</p> |
| | <div style="border: 1px solid black; padding: 5px; font-family: monospace;"> SETTINGS Alarm 1: 15ppm Delay 1: 2sec Alarm 2: 15ppm Delay 2: 10sec Offset: 0ppm Output: 0-20mA →set default </div> <p>At the SETTINGS menu the all settings can be reset to the factory default values. To reset to factory values once again press the button.</p> | <div style="border: 1px solid black; padding: 5px; font-family: monospace;"> DEFAULT set values: no change with +/- confirm with OK </div> <p>To change to “yes”, press the „+“ button. Confirm with “OK” to reset all settings to the factory default settings.</p> |

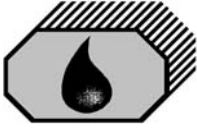





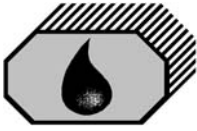



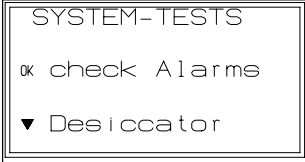
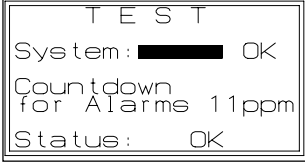
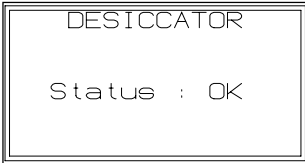

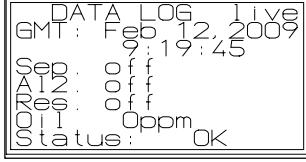

DECKMA HAMBURG GmbH

| | | |
|--|---|---|
| <div data-bbox="459 376 571 528" data-label="Image"> </div> <p>Pressing the SYS button directly leads into SYSTEM menu.</p> | <div data-bbox="769 362 1086 528" data-label="Image"> </div> <p>Select if you want information about the instrument or information about the measuring cell.</p> | <div data-bbox="1145 362 1453 517" data-label="Image"> </div> <p>Exit from SYSTEM-info menu by pressing the ESC button.</p> <div data-bbox="1134 689 1445 853" data-label="Image"> </div> <p>Exit from MEASURING CELL menu by pressing the ESC button.</p> |
| <div data-bbox="459 1048 571 1200" data-label="Image"> </div> <p>Pressing the ON button directly leads into the SYSTEM-OPTIONS menu.</p> | <div data-bbox="751 1034 1054 1200" data-label="Image"> </div> <p>Select if you want to activate the (optional) clean water valve or if additional information should be displayed.</p> | <div data-bbox="1134 1034 1445 1200" data-label="Image"> </div> <p>To change to "ON", press the "+" button. Confirm with "OK" to activate the optional clean water valve for a limited time.</p> <div data-bbox="1134 1417 1445 1581" data-label="Image"> </div> <p>Exit from information display by pressing the ESC button.</p> |

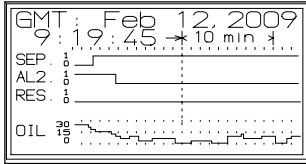

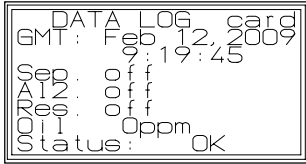
DECKMA HAMBURG GmbH

| | | |
|--|---|--|
|  <p>Pressing the TEST button directly leads into the SYSTEM-TESTS menu.</p> |  <p>Select if you want to activate the Alarms Test or if Dessicator status information should be displayed.</p> |  <p>Wait until Alarms Test is completed, as indicated by countdown value and progress bar.</p>  <p>Exit from information Desiccator status display by pressing the ESC button.</p> |
|--|---|--|

| | | |
|--|---|--|
|  <p>The LOG button leads into the data logger function.</p> |  <p>Initially the data logger displays the live data. With the  button it can be switched to the graphical display mode.</p> | |
|   <p>By pressing the LOG button twice the recorded data display mode is invoked.</p> |  <p>The data logger displays recorded data. With the  button it can be switched to the non-graphical display mode.</p> |  <p>The data logger displays recorded data. With the  button it can be switched to the graphical display mode.</p>   <p>In both data display modes the arrow buttons can be used to navigate to another date/time of recorded data.</p> |

NB: Changed values have to be confirmed by pressing the "OK" button. Otherwise the existing values remain valid.

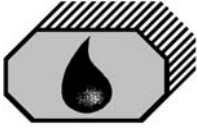

11.0 OPERATING INSTRUCTIONS

The OMD-2008 has one valve to switch over from sample water to clean water.

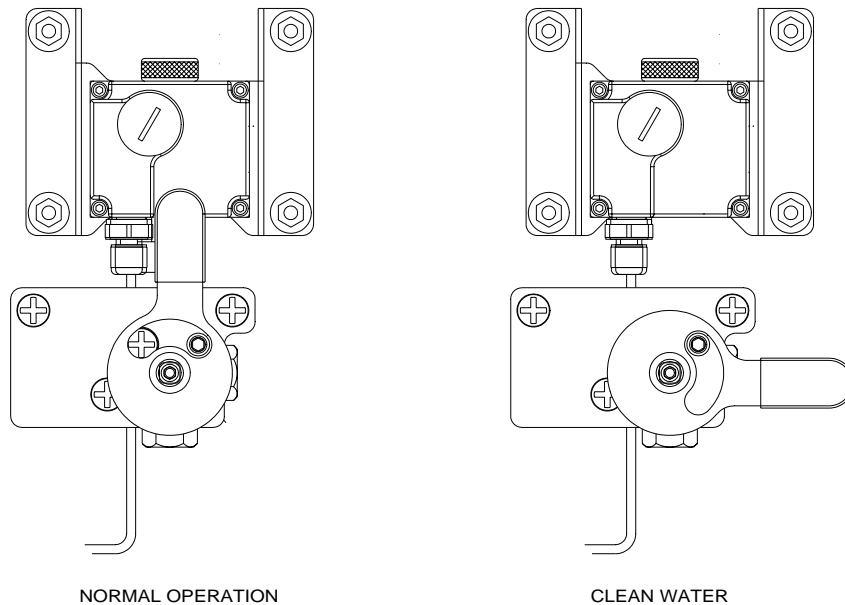

The OMD-2008 will automatically be in alarm condition whenever the valve handle is not in the sample position. Do not use excessive force to operate the handle. The OMD-2008 will only allow overboard discharge in Normal Operation setting of the valve handle.

Instrument start-up sequence:

- a) Switch on the power supply.
- b) Allow a period of time for water entering the sample tube.
- c) Flow oil free water through the system for a few minutes and check that the display show 0 to 2 ppm. If not, clean proper before adjusting the unit according section 10.4 "Settings - Offset".
- d) Switch the instrument sample supply from the clean water supply to the separator sampling point connection.
- e) The instrument is now ready for use.

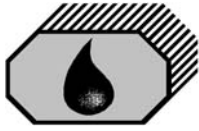

11.1 Operator Notes

- a) When oily water flows through the instrument the display will show the actual value of oil content.
- b) If the oil concentration exceeds the adjusted threshold (works adjustment 15 ppm), the alarm indicator 1 will be illuminated in intervals during the selected time delay before it change to steady light and the associated alarm relay will operate. Accordingly also the alarm indicator 2 will be illuminated and its associated alarm relay will take the appropriate shut down action.

12.0 OPERATOR MAINTENANCE

See Section 2 for important notes.

AT WEEKLY INTERVALS:

- a) Flush the cell with oil free water.
- b) Stop sample and oil free water flow.
- c) Unscrew and remove the cell cap.
- d) Insert a suitable Cell Cleaning brush (Art. No. 77555) into the cell and clean it with upwards and downwards motion through the entire length of the cell several times.
- e) Remove the Cell Cleaning brush and replace the cell cap.
- f) Open clean water valve and allow oil free water to flow through the instrument for a few minutes.
- g) Observe that the display is showing "0" to "2". If not, clean again.
- h) Examine the status of the desiccator (Chapter 10.4, TEST button). The Desiccator status display will indicate if the desiccator is worn out and working insufficient. If the desiccator status is any other then OK, the desiccator should be replaced. Additionally, the Measuring Cell dewpoint can be checked. The dewpoint should be lower then both sample temperature and clean water temperature.

Insufficient desiccator performance could result in condensation inside the measuring cell and wrong measurement and/or damage to optical components. Insufficient desiccator can easily be exchanged. Just unscrew the desiccator, replace the desiccator with a new one (Art. No. 79550). Make sure to close the desiccator cap properly. Allow the new desiccator some time to absorb the humidity inside the measuring cell.
- j) Switch valves to Normal Operation position

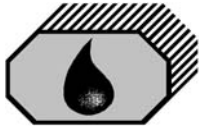

12.1 Manual Cell Clean Unit DH77780

Optional item if fitted

This unit facilitates cleaning of the cell without the need of removing the cell cap. Regular use of this device should prevent malfunction of the monitor due simply to fouling of the sample tube and all the inconvenience which this can cause.

Operating Instructions

- a) Ensure that the monitor is switched off and that there is a clean water supply through the cell.
- b) Activate the manual cell clean unit by pressing the handle several times.
- c) Switch the monitor back on and check the reading is between 0 to 2 ppm.
- d) Repeat a) to c) at least once a week or as necessary.

NB: The Manual Cell Clean Unit may also be used during normal operation with sample water, but in this case an alarm occurs because the wiper is passing the light source.

Spares: Wiper Seal DH77606

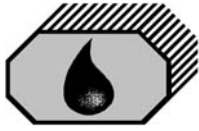

13.0 FAULT FINDING

See Section 2 for important notes.

The OMD-2008 will indicate several malfunctions in the status line of the display. Pressing the "OK" button will lead into an information window, similar to the items listed in the table below.

| Status | Reading | System-Alarm-LED | Alarm-circuit 1,2 | Reason | Servicing |
|----------|------------|------------------|-------------------|---|---|
| OK | 0..49 | Green / Blinking | Normal operation | Normal operation | - |
| OK | EE | Green / Blinking | Alarm | Sample reading is out of range: Oil content too high, dirty sample tube | Wait until oil content is within the range, clean sample tube |
| FW! | 0..49 / EE | Green / Blinking | Alarm | Freshwater is enabled | - |
| Sample? | EE | Red / Steady | Alarm | Meter is not able to measure the sample: no water in, oil content much too high, no light transmission possible | Check sample, clean sample tube according Page 20 |
| Flow! | 0..49 / EE | Green / Blinking | Alarm | Flow Switch (Terminals 15&16) open and/or Sample Valve Lever out of operation position | Check sample flow and valve positions |
| Com? | EE | Red / Steady | Alarm | No communication between computer unit and measuring cell | Check connection between computer unit and measuring cell |
| Datalog? | 0..49 / EE | Red / Steady | Alarm | Datalogging is not possible: no DECKMA memory card inserted | Insert the active memory card |
| | | | | Datalogging is not possible: a read only card has been inserted | Insert the active memory card |
| | | | | Datalogging is not possible: a new DECKMA memory card has been inserted, but has not been activated | Activate card or insert the active memory card |
| Desicc | 0..49 / EE | Green / Blinking | Normal operation | Measuring Cell humidity critically high (>40%rH) | Check/Replace Desiccator |
| Humid | 0..49 / EE | Green / Blinking | Normal operation | Sample temperatur below dewpoint. Instantaneous condensation possible | Check/Replace Desiccator |
| Int.Err | | Red / Steady | Alarm | Internal error | Restart the system |

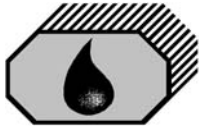

Important Information!

Cleaning of Glass Tube at 15 ppm Bilge Alarms OMD-2008

IMPORTANT:

NEVER DISASSEMBLE THE UNITS AS THIS MAY VOID THE CALIBRATION AND THE CERTIFICATION!

CLEANING HAS ONLY TO BE DONE THROUGH THE REMOVED CELL CAP BY
USING THE CLEANING BRUSH!

In most cases of high reading with clean water the measuring cell has a problem with internal coating of the glass tube. Just cleaning with brush and clean water will not help in this case.

Please carry out the following instructions to make sure, that the glass tube is really clean. Than the unit will show 0 to 2 ppm with clean water.

Check Measuring cell humidity readings and desiccator status. Desiccator status must be OK and dewpoint should be considerably lower then both sample temperature and clean water temperature. If not, change desiccant container and allow new desiccator to absorb the humidity inside the measuring cell.

Clean the glass tube by using the cleaning brush under assistance from some cleaner.

In certain cases iron oxide can be deposited inside the glass tube (brownish surface deposit on the glass tube), depending on environmental conditions on site. In this case some citric acid, juice from a fresh lemon may help, if you fill it into the glass tube and leave it at least over night before using the cleaning brush for removing the last dirt from the glass tube. Also, in cases of calceous deposits in the glass tube, treatment with some mild acidic cleaner, citric acid, or vinegar may allow removal of the deposits. Make sure, that the cleaning fluid will stay in the tube and is not draining. Sometimes the cleaning with citric acid has to be doen 2 or 3 times for at least 12 hours, depending on the thickness of the coating.

Additional use of some slightly abrasive cleaning powder or tooth paste may also assist in cleaning as a last resort. Please note that some powerful abrasives may scratch the glass surface, permanently damaging the instrument.

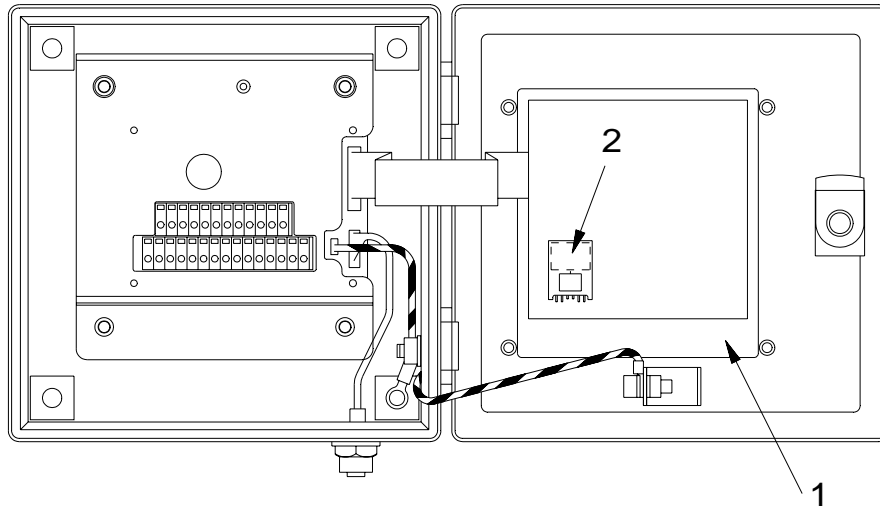
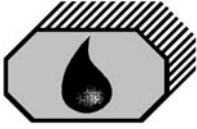

1: Display PCB

2: Memory Card

Fig. 6

13.1 Memory Card (refer to Fig. 6)

The Memory Card is on the backside of the Display PCB inside the computer housing. It is suitable for the life of the instrument, as it is calculated according to MEPC 107(49) to the required storage time of at least 18 months. When the card is full, the oldest entry will be overwritten, so that a replacement is not necessary. Under normal use the card should not be taken out, as this is linked with the specific system. The card can be read in other OMD-2008 units, but writing is only possible in the related system.

If no Memory Card is mounted or a card from another system is mounted, the unit will be in alarm conditions.

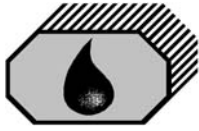

14.0 CALIBRATION

15 ppm Bilge Alarms built according MEPC.107(49) have to be protected against access beyond the checks of instrument drift, repeatability of the instrument reading and zero adjustment. For this reason the instrument is electronically sealed, so that only the manufacturer or his authorized persons, equipped with the related tools, are able to get access for changing the calibration.

To provide a simple procedure for check the instrument aboard ship, the OMD-2008 is constructed in that way, that the zero check also confirms the instrument drift within the specifications.

14.1 Calibration and repeatability check

- a) Switch off the power supply and stop any water flow.
- b) Clean the sample tube accurate by using a suitable cell cleaning brush as described under Section 12.0. Make sure, that the offset is correct at ± 0 .
- c) Run clean water through the instrument.
- d) If it is sure, that non aerated, clean water is in the instrument, the reading should be $0 \text{ ppm} \pm 2 \text{ ppm}$.
- e) Continue as described under Section 11.0.

Note § 4.2.11 of MEPC. 107(49):

The accuracy of the 15 ppm Bilge Alarms should be checked at IOPP Certificate renewal surveys according to the manufacturers instructions. Alternatively the unit may be replaced by a calibrated 15 ppm Bilge Alarm. The calibration certificate for the 15 ppm Bilge Alarm, certifying date of last calibration check, should be retained onboard for inspection purposes. The accuracy checks can only be done by the manufacturer or persons authorized by the manufacturer.

14.2 Function Test at Classification Survey and Port State Control

All 15 ppm Bilge Alarms leaving our works are calibrated according the requirements with an accuracy of better than $\pm 5 \text{ ppm}$ within the measuring range. The alarm points are pre-set to 15 ppm and can only be changed to a lower value on site. A setting to a higher value is not possible.

To provide a simple procedure for check the instrument aboard ship, the OMD-2008 is constructed in that way, that the zero check also confirms the instrument drift within the specifications. The Test button starts a self test routine and allows to put both alarms contacts into alarm condition. The instrument will count down from a assumed high reading (30ppm) downwards until the assumed value is equal to the actual measured ppm value. Note that this test will only switch the alarm contacts to non-alarm condition,

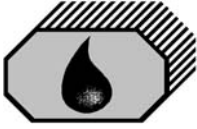

DECKMA HAMBURG GmbH

if the sample contains less than 15ppm oil content and all other conditions for proper measurement are OK.

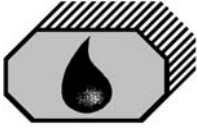

15.0 SPARE PARTS

When ordering spares, it is important to supply details of the type of monitor, part number of each spare required, its description and any relevant serial number.

| DESCRIPTION | ART-NUMBER |
|--|------------|
| Service Kit | 18570 |
| Desiccator | 79550 |
| Cell Cleaning Brush | 77555 |
| O-Ring Set | 77775 |
| Memory Card | 79186 |
| | |
| Service Exchange Measuring Cell (including new Calibration Certificate) | 2277500 |
| | |
| Optional Items | |
| Manual Cell Clean Unit | 77780 |
| Wiper Seal for Cell Clean Unit | 77606 |
| OMD-CR Memory Card Reader | 75185 |
| Function Test Kit | 18510 |
| | |
| | |

15.1 Recommended On Board Spares

| DESCRIPTION | ART-NUMBER |
|-------------------|------------|
| 1 off Service Kit | 18570 |
| | |

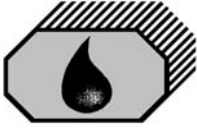

16.0 REMARKS

All the modifications and deviations from the standard form, which have to be carried out in the supply, should be attached at this paragraph.

Commissioned on:

Date

by:

Firm's Name

Remarks:



TYPENZULASSUNGSZEUGNIS
für 15 ppm Bilge Alarm

*Certificate of Type Approval for
 15 ppm Bilge Alarm*

**Ausgestellt im Namen der Regierung der
 BUNDESREPUBLIK DEUTSCHLAND**
 durch die **SEE-BERUFSGENOSSENSCHAFT**
*Issued under the authority
 of the Government of the FEDERAL REPUBLIC OF GERMANY
 by See-Berufsgenossenschaft*

Hiermit wird bescheinigt, dass der 15 ppm Bilge Alarm, die nachstehend aufgeführten Anlageteile umfasst, einer Prüfung unterzogen und gemäß den Anforderungen der technischen Beschreibung, enthalten in Teil 2 der Anlage zur Empfehlung der IMO-Entscheidung MEPC.107(49), erprobt wurde.

This is to certify that the 15 ppm Bilge Alarm, comprising the equipment listed below, has been examined and tested in accordance with the requirements of the specifications contained in part 2 of the annex to the Guidelines and Specifications contained in IMO-Resolution MEPC.107(49).

Dieses Zeugnis ist nur für nachstehendes Ölgehaltsmessgerät gültig.
This certificate is valid only for the 15 ppm Bilge Alarm referred to below.

15 ppm Bilge Alarm geliefert durch: **DECKMA HAMBURG GmbH, Kieler Straße 316, D-22525 Hamburg,**
15 ppm Bilge Alarm supplied by:

Typbezeichnung: **OMD 2008**
under type and model designation and incorporating:

Die Analyse-Einheit des 15 ppm Bilge Alarms wurde hergestellt durch: **DECKMA HAMBURG GmbH**
15 ppm Bilge Alarm analysing unit manufactured by:

Zusammenstellungszeichnung Nr.: **DH10820 Bl. 1 + Bl. 3** Datum: **09.12.2008;09.12.2008**
to specification/assembly drawing No.: DH77500, DH77100 date: 09.12.2008;09.12.2008

Der elektronische Teil des 15 ppm Bilge Alarms wurde hergestellt durch: **DECKMA HAMBURG GmbH**
Electronic section of 15 ppm Bilge Alarm manufactured by:

Zusammenstellungszeichnung Nr.: **DH10820 Bl. 1 + Bl. 3** Datum: **09.12.2008;09.12.2008**
to specification/assembly drawing No.: DH77500, DH77100 date: 09.12.2008;09.12.2008

Versorgungspumpe hergestellt durch: **--**
Sample feed pump manufactured by:

Zusammenstellungszeichnung Nr.: **--** Datum: **--**
to specification/assembly drawing No.: date:

Probenaufbereitungseinheit hergestellt durch: **--**
Sample conditioning unit manufactured by:

Zusammenstellungszeichnung Nr.: **--** Datum: **--**
to specification/assembly drawing No.: date:

Der 15 ppm Bilge Alarm ist für die Verwendung gemäß Regel 16(5) geeignet.
The 15 ppm Bilge Alarm is acceptable for use in accordance with regulation 16(5).

Eine Kopie dieses Zeugnisses soll jederzeit auf jedem Schiff mitgeführt werden, das mit diesem 15 ppm Bilge Alarm ausgerüstet ist.
A copy of this Certificate should be carried aboard a vessel fitted with this 15 ppm Bilge Alarm at all times.

Dieses Typenzulassungszeugnis bleibt über das nachstehende Datum hinaus in Kraft, sofern kein Widerruf erfolgt. Ein Widerruf für auf einem Schiff eingebaute Einrichtungen kann z.B. erfolgen, wenn diese nicht gefahren und/oder nicht gewartet und/oder nicht funktionsbereit sind und/oder nicht innerhalb einer angemessenen Frist an zukünftige Bestimmungen angepasst werden können.

This certificate of type approval is in force beyond the below mentioned date unless it is revoked. A revocation of the equipment installed aboard the ship can follow, but is not limited to, if the equipment is not maintained and/or is not in good working order and/or the equipment can not be modified within an appropriate time frame, due to future regulatory standards.

Daten und Ergebnisse der Erprobungen siehe Anhang.
Test data and results attached as Appendix.

Dieses Typenzulassungszeugnis ist gültig bis: **30.09.2014**
This certificate of type approval is valid until:

Ausgestellt in Hamburg am: **01.10.2009**
Issued at Hamburg on:

Zulassungs-Nr.: **320 032**
Certificate-No.:



SEE-BERUFSGENOSSENSCHAFT
- SCHIFFSSICHERHEITABTEILUNG -

[Handwritten Signature]
 Unterschrift
 Signature

Anhang zum Typenzulassungszeugnis für 15 ppm Bilge Alarm

Appendix to the certificate of type approval for an 15 ppm Bilge Alarm

Daten und Ergebnisse der Erprobungen, durchgeführt an einem 15 ppm Bilge Alarm gemäß Teil 2 der Anlage zu den Richtlinien und Anforderungen der IMO-EntschlieÙung MEPC.107(49).

Test data and results of tests conducted on a 15 ppm Bilge Alarm in accordance with Part 2 of the Annex to the guidelines and specifications contained in IMO-Resolution MEPC.107(49).

15 ppm Bilge Alarm vorgestellt durch: DECKMA HAMBURG GmbH
15 ppm Bilge Alarm submitted by:

Ort der Erprobungen: DECKMA HAMBURG GmbH, Kieler Straße 316, D 22525 Hamburg,
Test location:

Stelle, die die Prüfung durchgeführt hat: Sec-Berufsgenossenschaft Hamburg
Organization conducting the test:

Verfahren der Probenanalysen: IMO-Verfahren gemäß EntschlieÙung MEPC.107(49) (ISO 9377-2)
Method of sample analysis: IMO-method acc. to resolution MEPC.107(49) (ISO 9377-2)

Analysen der Proben durch: Institut Fresenius GmbH, Im Maisel 14, D-65232 Taunusstein-Neuhof
Samples analysed by:

Die Erprobung des elektronischen Teils des 15 ppm Bilge Alarms ist unter Umweltbedingungen gemäß Teil 3 der Anlage zu den Richtlinien und Anforderungen der IMO-EntschlieÙung MEPC.107(49) durchgeführt worden. Die Anlage arbeitete bei Beendigung der jeweiligen Erprobung, die im Bericht über die Prüfung bei Umgebungsbedingungen festgelegt ist, zufriedenstellend.

Environmental testing of the electronic section of the 15 ppm Bilge Alarm has been carried out in accordance with part 3 of the annex to the Guidelines and Specifications contained in IMO resolution MEPC.107(49). The equipment functioned satisfactorily on completion of each test specified on the environmental test protocol.

Empfehlungen und Informationen des Herstellers über den Gebrauch von Reinigungsmitteln.
Manufactures' recommendations and information concerning the use of cleansing agents

Verwendung von schnell trennenden Reinigungsmitteln.
Detergents of quick separating type.

Der 15 ppm Bilge Alarm Serien-Nr.: **entspricht dem geprüften Typ.**
The 15 ppm Bilge Alarm serial No.: *complies with the tested type.*

| | | | |
|-------------------------------------|--------------------------------------|---|--|
| Ort <i>Place</i> | Datum <i>date</i> | Firmen- stempel - <i>Company stamp</i> | Unterschrift <i>Signature</i> |
|-------------------------------------|--------------------------------------|---|--|

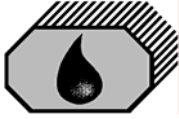

DECKMA HAMBURG GmbH

DECKMA Decksmaschinen und Automation Vertriebsgesellschaft in Hamburg mbH

DECKMA HAMBURG GmbH • Kieler Straße 316 • 22525 Hamburg • Germany

Works/Office/Delivery Address:

Kieler Straße 316
22525 Hamburg
Germany

Telephone: +49 (0)40 54 88 76 - 0

Telefax: +49 (0)40 54 88 76 - 10

E-Mail: post@deckma.com

Internet: www.deckma.com

TO WHOM IT MAY CONCERN

VAT-Registration No.: DE 118 540 659

Your Ref.:

Your letter dated:

Our Ref.:

Date: 24.08.2010

DECLARATION OF CONFORMITY

We, DECKMA HAMBURG GmbH,
declare under our own responsibility that the product

15 ppm Bilge Alarm, Type: OMD-2008
manufactured by DECKMA HAMBURG GmbH
Kieler Strasse 316, 22525 Hamburg, Germany

complies with the Maritime Equipment Directive 96/98 EC, as amended by Directive 2008/67/EC.

The equipment has been tested to verify compliance with MEPC.107(49) as per Type Examination (Module B) Certificate No. 320.032 and related Certificate of Conformity According to Module F, Certificate No. 320.032.

DECKMA HAMBURG GmbH

ppa. Wolfgang Rathjen



See-Berufsgenossenschaft
Prüf- und Zertifizierungsstelle
im BG-PRÜFZERT

European notified body
Identification number 0736

**Deutsche Gesetzliche
Unfallversicherung**



EC-Type Examination (Module B) Certificate

Certificate-No. 320.032

Name and address of the manufacturer: DECKMA Hamburg GmbH, Kieler Straße 316, 22525 Hamburg, Germany

Date of issue: **01.10.2009**

Annex A.1 Item No & Item designation: **A.1/2.3 – Oil-content meters**

Product designation: Oil-in-water monitor

Product Type: **OMD - 2008**

Intended purpose: Oil content meter (15-ppm alarm) for oily water separating equipment on sea going vessels acc. MARPOL 73/78, Annex I

Testing based on (Specific standard): **IMO Resolution MEPC.107(49) for oil content meters and oily water separating equipment in acc. with MARPOL 73/78, Annex I**

Remarks:

The type tested was found to be in compliance with the Marine-pollution prevention requirements of Marine Equipment Directive (MED) 96/98/EC as amended by Directive 2009/26/EC subject to any conditions in the schedule (part of this certificate).

This certificate may only be used in connection with module(s) **F** of this directive.

Expiry date: **30.09.2014**

Signature (Seifer)

The approval of the installed equipment will be in force beyond the validity date until it is revoked!

Note 1: This certificate will not be valid if the manufacturer makes any changes or modifications to the approved equipment, which have not been notified to, and agreed with the notified body named on this certificate.

Note 2: Should the specified regulations or standards be amended during the validity of this certificate, the product(s) is/are to be re-approved prior to it/they being placed on board vessels to which the amended regulations or standards apply.

Note 3: The Mark of Conformity may only be affixed to the above type approved equipment and a Manufacturer's Declaration of Conformity issued when the production-control phase module (D, E, or F) of ANNEX B of the Directive is fully complied with and controlled by a written inspection agreement with a notified body.

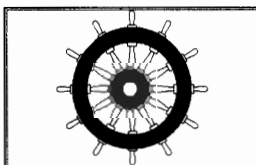

xxxx/yy

Note 4: "Wheelmark" Format

YY Last two digits of year mark affixed.

XXXX Notified Body number undertaking surveillance module

Technical data/approved drawings and additional conditions and remarks:

The Prüf- und Zertifizierungsstelle der See-Berufsgenossenschaft verifies and certifies the conformity of the a.m. product with the Directive 96/98/EC of the Council, as amended by Directive 2008/67/EC, Annex B, Module F (Product Verification), section 5, Statistical Verification.

All products will be divided into identical lots of 200 pieces each, starting with serial number 3001001. Three (3) random samples will be drawn from each lot and individually examined.



**U. S. Department of Homeland Security
United States Coast Guard
Certificate of Approval**

Coast Guard Approval Number: 162.050/9103/0

Expires: 18 January 2016

OIL POLLUTION PREVENTION EQUIPMENT
The following device has been tested in accordance
IMO Resolution MEPC.107(49)

DECKMA HAMBURG GmbH
Kieler Strabe 316
HAMBURG D-22525
GERMANY

Model OMD - 2008; 15 ppm bilge alarm

This is to certify that the 15 ppm bilge alarm, listed above, has been examined and tested in accordance with the Guidelines and Specifications contained in IMO resolution MEPC.107(49).

Equipment manufactured by DECKMA HAMBURG GmbH to specification/assembly drawing no. DH10820 and DH 77500 dated 09/12/2008. Control equipment manufactured by DECKMA HAMBURG GmbH to specification/assembly drawing no. DH77100, DH77200, and DH77300 dated 09/12/2008.

A copy of this certificate should be carried aboard a vessel fitted with this equipment at all times.

IMO Certificates of Type Approval do not expire and are valid for equipment manufactured at any time during the period of validity of this certificate.

Test data and results attached in the appendix.

This certificate documents compliance with 46 CFR 162.050.

*** END ***

THIS IS TO CERTIFY THAT the above named manufacturer has submitted to the undersigned satisfactory evidence that the item specified herein complies with the applicable laws and regulations as outlined on the reverse side of this Certificate, and approval is hereby given. This approval shall be in effect until the expiration date hereon unless sooner canceled or suspended by proper authority.



GIVEN UNDER MY HAND THIS 18th DAY OF
JANUARY 2011, AT WASHINGTON D.C.

S. J. KELLY
Chief, Engineering Division
U.S. Coast Guard Marine Safety Center



5-15 ppm alarm

5-15 ppm alarme

CANADA
CERTIFICATE OF TYPE TEST FOR BILGE ALARMS
CERTIFICAT D'AGRÉMENT PAR TYPE DES ALARMES POUR EAUX DE CALE

This is to certify that the equipment listed below has been examined and tested in accordance with the requirements of the Specifications contained in Part II of the Annex to the Guidelines and Specifications contained in IMO resolution MEPC 107(49). This Certificate is valid only for the Bilge Alarm referred to below. *Il est certifié que l'alarme pour eaux de cale comprenant les éléments ci-après a été examinée et soumise à des essais conformément aux dispositions des spécifications qui font l'objet de la Partie II de l'annexe aux Directives et spécifications contenue dans la résolution 107(49) de l'OMI. Le présent certificat n'est valable que pour une alarme pour eaux de cale du type décrit ci-dessous :*

Bilge Alarm supplied by DECKMA HAMBURG GmbH, Kieler Strabe 316, D-22525 Hamburg
Alarme pour eaux de cale fournie par :

Under type and model designation OMD - 2008
and incorporating
Type et désignation du modèle comprenant:

Bilge Alarm analysing unit manufactured by DECKMA HAMBURG GmbH
Dispositif d'analyse de l'alarme pour eaux de cale fabriqué par :

To specification / drawing numbers DH10820 B1. 1 + B1 . 3. DH77500, DH77100
Conformément à la spécification/au schéma n° :

Electronic Section of Bilge Alarm manufactured by: DECKMA HAMBURG GmbH
Élément électronique de l'alarme pour eaux de cale fabriqué par:

To specification/drawing numbers: DH10820 B1. 1 + B1 . 3. DH77500, DH77100
Conformément à la spécification/au schéma n° :

**THIS SYSTEM IS ACCEPTABLE FOR THE FOLLOWING APPLICATION:
CE DISPOSITIF EST CONÇU POUR LES UTILISATIONS SUIVANTES :**

This Bilge Alarm is acceptable for use in accordance with regulation 14.7.
Cette alarme pour eaux de cale est acceptable et peut être utilisée conformément à la règle 14.7.

This Bilge Alarm meets the specification for a **5 ppm** unit, as contained in the Standard for 5 ppm Bilge Alarms for Canadian Inland Waters - TP 12301, in accordance with the Regulations for the Prevention of Pollution from Ships and for Dangerous Chemicals. *Cette alarme pour eaux de cale satisfait aux spécifications pour une unité à 5 ppm, selon la « Norme relative aux alarmes à 5 ppm pour eaux de cale (Eaux internes du Canada) » - TP 12301, conformément au Règlement sur la prévention de la pollution par les navires et sur les produits chimiques dangereux.*

Test date and results: 20 April 2010 as per test Certificate108 1285256 OMD2008
Date et résultats des essais :

A COPY OF THIS CERTIFICATE SHOULD BE CARRIED ABOARD A VESSEL FITTED WITH THIS EQUIPMENT AT ALL TIMES. UN EXEMPLAIRE DU PRÉSENT CERTIFICAT D'ESSAIS DEVRAIT SE TROUVER EN PERMANENCE À BORD D'UN BÂTIMENT ÉQUIPÉ DE CE MATÉRIEL.

Paul Topping, Manager, Environmental Protection
Marine Safety, Ottawa, Ontario *Gestionnaire, Protection environnementale*
Sécurité maritime, Ottawa, Ontario

17 May 2010
Date



**СВИДЕТЕЛЬСТВО
О ТИПОВОМ ОДОБРЕНИИ ДЛЯ СИГНАЛИЗАТОРА
О СОДЕРЖАНИИ НЕФТИ В СБРОСЕ (15 МЛН⁻¹)**

**CERTIFICATE
OF TYPE APPROVAL FOR 15 PPM BILGE ALARM**

Настоящим удостоверяется, что сигнализатор, включающий перечисленное ниже оборудование, проверен и испытан в соответствии с требованиями части 2 Приложения к Руководству и техническим требованиям, содержащимся в резолюции ИМО МЕРС.107(49). Настоящее Свидетельство действительно только для сигнализатора, указанного ниже.

This is to certify that the 15 ppm bilge alarm, comprising the equipment listed below, has been examined and tested in accordance with the requirements of the specifications contained in part 2 of the Annex to the Guidelines and Specifications contained in IMO resolution MEPC.107(49). This Certificate is valid only for the 15 ppm bilge alarm referred to below.

Сигнализатор типа и модели _____ OMD-2008
15 ppm bilge alarm under type and model designation

поставляется _____ DECKMA HAMBURG GmbH, Germany
supplied by

и включает _____
and incorporating

анализатор содержания нефти, изготовленный _____ DECKMA HAMBURG GmbH, Germany
15 ppm bilge alarm analysing unit manufactured by

по техническим условиям/сборочному чертежу № _____ DH77500, DH77100, DH10820 BL.1+BL3
to specification/assembly drawing No.

дата _____ 09.12.2008
date

электронную секцию сигнализатора, изготовленную _____ DECKMA HAMBURG GmbH, Germany
electronic section of 15 ppm bilge alarm manufactured by

по техническим условиям/сборочному чертежу № _____ DH77500, DH77100, DH10820 BL.1+BL3
to specification/assembly drawing No.

дата _____ 09.12.2008
date

~~*пробоотборный насос, изготовленный~~ _____
~~*sampling pump manufactured by~~

по техническим условиям/сборочному чертежу № _____
to specification/assembly drawing No.

09.12.2008 _____ дата _____
date

~~*пробоотборное устройство, изготовленное~~ _____
~~*sampling unit manufactured by~~

по техническим условиям/сборочному чертежу № _____
to specification/assembly drawing No. _____

дата _____
date _____

Сигнализатор приемлем для использования в соответствии с правилом 16(5)
The 15 ppm bilge alarm is acceptable for use in accordance with regulation 16(5)

Копия настоящего Свидетельства должна постоянно находиться на борту судна, оснащенного данным сигнализатором.
A copy of this Certificate is to be carried aboard a vessel fitted with this 15 ppm bilge alarm at all times.

Исходные данные и результаты испытаний приведены в Дополнении.
Test data and results attached as Appendix.

№ _____
No. **11.00114.120**

07.07.2011

(дата выдачи)
(date of issue)

Российский морской регистр судоходства
Russian Maritime Register of Shipping



(подпись уполномоченного лица, выдавшего Свидетельство)
signature of authorized official issuing the Certificate





格式 CP181
Form

中国船级社

CHINA CLASSIFICATION SOCIETY

编号 HB10T00032_01
No.

15 PPM 舱底水报警装置型式认可证书
CERTIFICATE OF TYPE APPROVAL FOR 15 PPM BILGE ALARM

This is to certify that the 15 ppm Bilge Alarm, comprising the equipment listed below, has been examined and tested in accordance with the requirements of the specifications contained in part 2 of the annex to the Guidelines and Specifications contained in IMO resolution MEPC.107(49). This Certificate is valid only for the 15 ppm Bilge Alarm referred to below.

15 ppm Bilge Alarm supplied by DECKMA Hamburg GmbH

under type and model designation

and incorporating: OMD-2008

15 ppm Bilge Alarm analysing unit manufactured by DECKMA Hamburg GmbH

to specification/assembly drawing No. DH10820 page 1 & 3, date 12.09.2008
DH77500, DH77100

Electronic section of 15 ppm Bilge Alarm manufactured by DECKMA Hamburg GmbH

to specification/assembly drawing No. DH10820 page 1 & 3 date 12.09.2008
DH77500, DH77100

The 15 ppm Bilge Alarm is acceptable for use in accordance with Regulation 16 (5).

A copy of this Certificate should be carried aboard a vessel fitted with this 15 ppm Bilge Alarm at all times.

Test data and results attached as appendix.

Official stamp

Signed [Signature] (Kong Qingcai)

Dated this Oct. 13 day of C5 2010

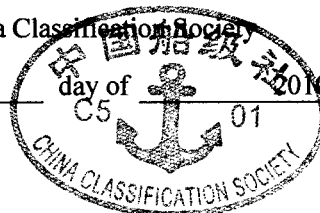

*Delete as appropriate.

